

## ELECTRO-AIMANT DE VERROUILLAGE DE HAYON DE BUS

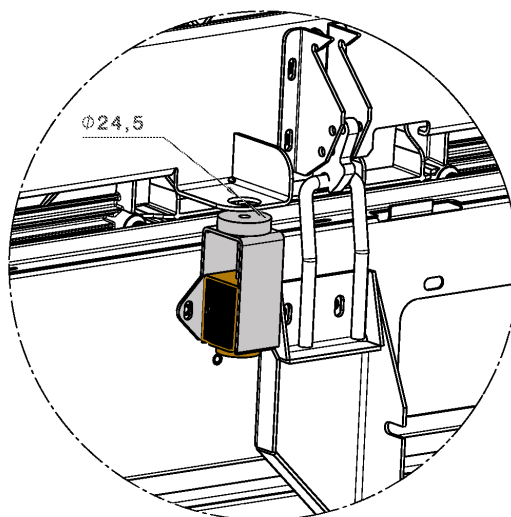

Schéma 3D de son installation:

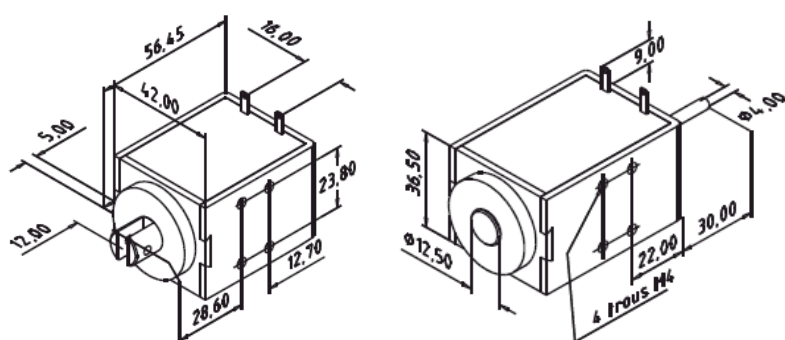

Electro-aimant utilisé : **7165**

DIMENSIONS (mm)	ALIMENTATION	MASSE (g.)	COURSE (mm)
42 x 56.45 x 36.5	6 à 220 VDC – 6 à 230 VAC	400	22

Principe :

*Electro-aimant équipé d'un doigt de verrouillage. Cet ensemble constitue un système anti effraction du capot moteur du bus.*

